

Zetor
ENGINEERING



ATV ZETOR GERLACH 4X4

ATV Zetor Gerlach 4x4

The latest generation combat vehicle

Named after the highest peak in Slovakia, the ambitions for this armoured vehicle are equally high. The Gerlach's latest success, which has resonated across the international military & defence scene, is to have attracted the German company Rheinmetall Protection Systems as a strategic partner for the project.



The idea of the tactical armoured vehicle ATV Zetor Gerlach 4x4 came to the developers of Zetor Engineering Slovakia, a.s. back in 2016. Work on preparing the project began in the same year. In addition to Czech and Slovak developers and designers, experts with real ex-

perience of combat conflicts in Iraq, Afghanistan and Ukraine were also involved. The design of the chassis and its tuning for the most difficult terrain saw also the involvement of a long-time Rally Dakar driver and parts designer for this extreme motoring competition. The drafting and

approval of the feasibility study through to the vehicle prototype in the end took the developer team only about two years, and the Gerlach was premiered in May last year at the IDEB in Bratislava, where it immediately gained the attention of the international professional public.



■ Výroba ATV Zetor Gerlach 4x4

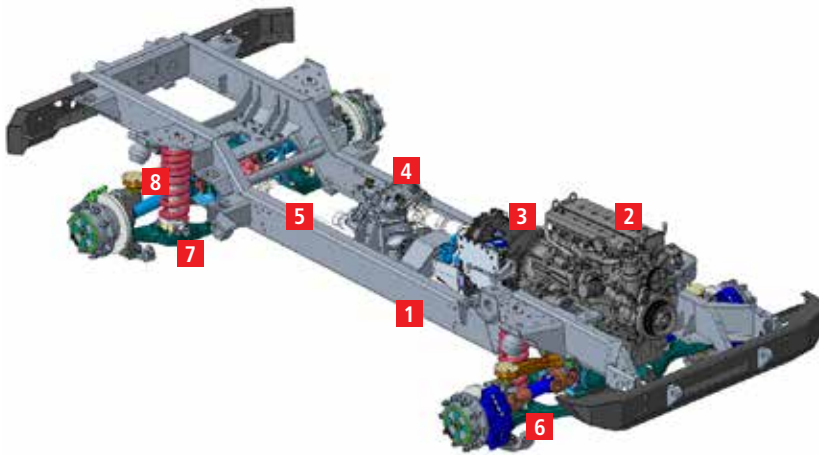

■ Diagram of chassis transmission: (1) frame, (2) motor, (3) gearbox, (4) descending gearbox, and (5) universal joint, (6) front axle, (7) rear axle, (8) coil suspension with hydraulic shock absorber

Benefits of the new solution

As a new generation tactical armoured vehicle, the Gerlach provides all the benefits of a new timeless solution. In addition to taking into account the latest technical and design requirements for a vehicle of this category, consideration was also given to further evolution cycles in terms of the vehicle's dimensions, overall design and open electronic architecture. Thus, the Gerlach not only responds to the current needs of armed forces, but is also fully adaptable to new demands over the coming decades.

The vehicle is constructed exclusively from EU components, including a successfully tested chassis. From the customer's point of view, this means trouble-free logistics, availability of spare parts and low servicing costs.

Unique chassis

The Gerlach is built on the new Rolling Chassis ZETOR designed on the basis of many years' experience with heavy off-road technology, and with an emphasis on power traction and dynamic parameters.

The high mobility is based on the odd-runner principle of suspension comprising independent wheel units and supported by stabilisation at high speeds and manoeuvres requiring exceptional lateral and longitudinal stability. It is a solution that ensures maximum adhesion, even in the most difficult conditions.

The Zetor Rolling Chassis design has also, from the assignment been conceived as a stand-alone product – a platform on which Zetor Engineering, in collaboration with the customer, can develop the required superstructure, or the customer can realise it separately.

Excellent mobility and dynamics

The drive system is based on a German 6-cylinder MTU engine with an output of 240

kW (326 hp), which excels in above-standard torque of 1300 Nm. The engine works with a special 6-speed automatic transmission for maximum power utilisation across the range of revolutions. Power distribution to independently suspended wheels is transmitted by a uniquely balanced universal joint via a descending gearbox manufactured by Meritor, one of the world's leading torque distributors for all-wheel drive. All these main chassis components are part of the Zetor Rolling Chassis. With this solution, the Gerlach has gained exceptional dynamics when its 14.2 tonne full-load power ratio reaches 17 kW/t.

The Gerlach is able to tow trailers of up to 12 tons, which means it can also be used as a tractor for artillery systems. During the special load tests on the test circuit, it also showed much greater tractive force when it started running in a hitch with a 28-ton tractor and then circled with it 1 hour after the circuit while maintaining the required parameters.

Some of the Gerlach's capabilities:

- During tests in military premises, it managed a full load of 14 tons a terrain step 0.5 m high and a trench 1 m wide.
- It also managed a 100% (45°) climb under full load. On long stretches it comfortably handles a 60% slope.
- On the test circuit it reached a maximum speed of 125 km an hour, even in rainy weather. It also proved its traction power, when it got started with a 28 tonne tractor in tow, and circled around the circuit with it for 1 hour.
- In tests in the grounds of the Vyškov VTÚPV it parked with the engine switched off at an angle of 83.9% (40°). The vehicle was weighed to a maximum weight of 14.2 tons.
- It has received NATO ballistic resistance certification STANAG 4569 AEP-55 Volume 1, Level 3.
- It has successfully passed antimine protection tests confirming the declared resistance to a load of 8 kg TNT under the cab and under the axle (NATO STANAG 4569 AEP-55 Volume 2, Level 3a, 3b).
- Special acoustic tests confirmed low noise and vibration levels in the cab, of 65 dB.

Excellent in terrain

The vehicle provides superior capabilities in difficult terrain on various surfaces, including sand, mud or snow. In addition to its special chassis and massive torque, it is also supported by a 14 R20 wheel size with a central tire inflation system and a clear height of up to 465 mm.



■ Special chassis, massive torque and ground clearance of up to 465 mm ensure the vehicle's excellence in terrain

The vehicle is, of course, equipped with an inter-axle differential lock and front and rear axle differential locks. The shutters are locked according to the type of surface (road, terrain, off-road) and terrain difficulty. First, the inter-axle differential closes, then the rear and in difficult terrain (deep mud, deep snow, wading water obstacles, engagement) the front differential also closes. The shutters are operated electro-pneumatically.

The Gerlach confirmed its skills in the field during tests at the Záhorie Military Technical and Testing Institute as well as at the Military Technical Institute of Ground Forces – branch plant VTÚPV Vyškov, where it climbed a terrain step with a height of 0.5 m and overcame a one-metre wide trench. When overcoming both obstacles the vehicle had a load of 6x120 kg, consisting of the crew in full equipment and a 1-ton load in the cargo compartment.

The vehicle also managed the target of a 100% climb when, with a 14-tonne load, it handled an approach angle of 45°. On long stretches it comfortably handles a 60° climb.

Tests at VTÚPV Vyškov also verified the effectiveness of the parking brake system, which can play an important role in crisis situations. The general requirement of armies is to hold the vehicle with the motor switched-off on a 60% slope, i.e. at an angle of 30°. The Gerlach held itself at an angle of 78% (38.2°) in the uphill direction and at an angle of 83.9% (40°) in the downhill direction. During the tests, the vehicle was weighted to the maximum weight of 14.2 tons.

Solutions for maximum protection

The Gerlach uses multi-stage design elements to maximize protection of the vehicle's crew. The Zetor Rolling Chassis again

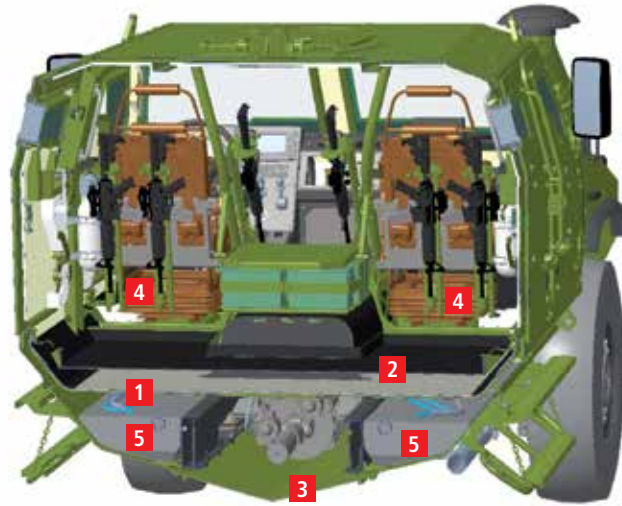

■ Vehicle section: (1) floor, (2) suspended floor, (3) V-shield, (4) anti-mine seats with side and ceiling fixtures, (5) independent fuel tanks

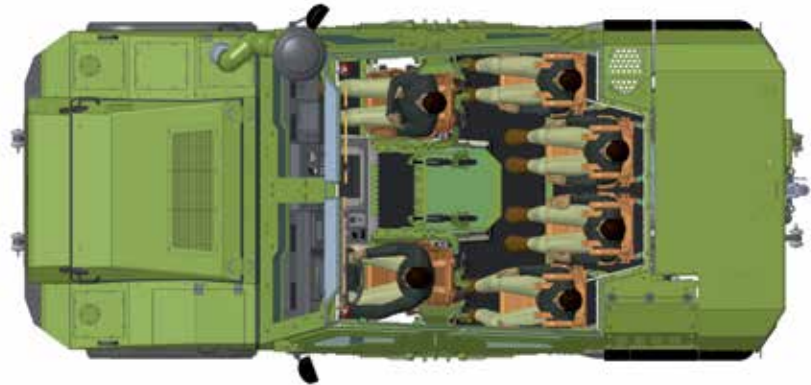

■ Layout of the 6-member crew in the Gerlach safety capsule

plays an important role here. Its ribbed portal frame is able to withstand high dynamic loads and is one of the main pillars of its anti-mine protection.

In order to achieve maximum protection for the crew, the developers chose an approach where the vehicle is divided into three main parts – the engine housing, the rear part with variable cargo space and the central part, which is a security armoured cabin.

Safety capsule

The cabin is designed as an overpressure armoured capsule resistant to IEDs. It is attached independently of the chassis of the vehicle, so if it is damaged by a mine, the crew remains protected. In contrast to conventional 4 – 5 seaters, its unprecedented safety volume of 7.7 m³ offers seats for up to 6 crew members with a height of up to 190 cm and a weight of 120 kg, including kit. In the event of an emergency,

■ Armoured cabin – the vehicle's safety capsule passed the NATO anti-mine resistance test at the level STANAG 4569 AEP-55 Volume 2, Level 3a, 3b. The tests were carried out at MBDA Deutschland near Schrobenhausen, Germany, with the participation of the vehicle manufacturer – Zetor Engineering Slovakia, a. s., the manufacturer of the anti-mine kit – Rheinmetall Protection System GmbH and the German state-certified testing laboratory Beschussamt Ulm



“The combination of protection, mobility and other benefits makes this vehicle an extremely competitive solution. We will be happy to take part in the further progress of the project,” said Dr. Manfred Salk, CEO of Rheinmetall Protection Systems GmbH.

it also provides room for two additional crew members (without a seat). At the same time, the cab design allows for very quick exiting.

Crew safety is also enhanced by additional modular armour along with a separate and suspended double deck and anti-mine V shield.

Other elements enhancing crew safety are special seats absorbing dynamic effects in explosions, as well as safety glass.

In addition to safety, comfort was also considered. Special elements have been incorporated to suppress noise and vibration disturbances. Special acoustic tests carried out in cooperation with Siemens confirmed a low noise level of 65 dB (note: 60 dB = noise level in normal human speech).

Strategic cooperation with Rheinmetall Protection Systems

Expert evaluations of domestic and foreign experts have from the outset said that



■ Virtually any weapons system up to 500 kg can be mounted on the vehicle roof

metall Protection Systems GmbH, the world leader in combat vehicle protection.

The agreement concerns the joint development of the Gerlach’s ballistic and anti-mine resistance solutions. These are therefore key elements of the vehicle, guaranteeing maximum safety for the crew during combat deployment. The German company sees great potential in the Slovak project, which was confirmed by the CEO of Rheinmetall Protection Systems, Dr Manfred Salk “The combination of protection, mobility and other benefits

circles is understandable also because Rheinmetall Protection Systems armour protection is a byword and guarantee of the highest security around the world.

Close cooperation

On the basis of a strategic cooperation agreement, the German company has also become a supplier of a comprehensive and certified safety cabin solution. The entire process, starting with the selection of materials through welding and construction work, including technological processes, is subject to strict military standards (MIL-TL). The most stringent standards will consequently be applied in the manufacture of cabins in Slovakia, as well as in other countries where the Gerlach is to be produced.

If the vehicle succeeds in competition in Slovakia, and thus consequently in serial production, the German partner has declared an interest in transferring the complete manufacture of ballistic and anti-mine equipment to Slovakia. Strategic cooperation will though, in addition to ballistic and anti-mine protection, be developed also in new areas, such as Protection Systems Land (Rapid Obscuring System, Smoke Vehicle Protection System, Active Defence System, Weapon Stations, etc.)

It is likewise good news for the Slovak defence industry that Rheinmetall Protection Systems intends to establish also the production of additional ceramic armour systems in Slovakia.

Cooperation with the world leader in ballistic and antimine protection has not come about by chance, but is the result of hard, professional work. The foundations for the cooperation were laid right at the stage of design and construction of the vehicle



■ ATV Zetor Gerlach 4x4 in testing

the Gerlach is competitive also internationally. The vehicle’s parameters and capabilities have also attracted the attention of several renowned companies in the worldwide defence industry, some of which have become project partners. The most recent strategic cooperation agreement was signed with Rhein-

makes this vehicle an extremely competitive solution. We will be happy to take part in the further progress of the project,” as reported in Army Recognition, one of the world’s leading media mapping the defence industry.

The interest of the world media and the response in international military & defence

prototype. At that time, it was implemented under the auspices of IBD Deisenroth Engineering GmbH, an internationally recognised supplier of military vehicle protection systems. Rheinmetall AG was working closely with the IBD group and on 1 June was eventually taken over into its portfolio. "The German side provided expertise and proposed several improvements in the field of ballistic and antimine protection. Subsequently, intensive cooperation on engineering and construction activities started," explains project manager Pavel Bušta.

All modifications were subsequently subjected to simulations and rigorous tests at the German state certified testing laboratory Beschussamt Ulm. Crew protection has been a top priority for the Gerlach vehicle project



■ View into the Gerlach arranged in the standard 2 + 4 crew configuration.

weapons used in current conflicts. The antimine resistance of the vehicle is at NATO level STANAG 4569 AEP-55 Volume 2 Level 3a, 3b. The Gerlach can withstand an anti-tank mine in the strength of up to 8 kg TNT under the axle and under the cab. This level of protection has been successfully tested by the Beschussamt Ulm State Testing Agency.

According to the results from the latest tests, the vehicle concept makes it possible to achieve a level of antimine protection according to STANAG 4569 AEP-55 Volume 2 Level 4a, 4b.

High variability

Other advantages of the Gerlach include the highly variable 2.3 m³ cargo compartment, which can carry an additional 1.5 tons of kit or equipment. The cargo compartment is separated from the crew compartment, diverting any destructive forces in the event of an explosion.

Vehicle versions can be quickly changed according to mission requirements. The basic version of the vehicle weighing 12.5 tons already incorporates filter ventilation with air conditioning and protection against chemical, biological and nuclear weapons.

Ready to fight

The Gerlach also allows for a whole range of superstructures. The roof has been reinforced by rigidity adjustments for shocks in the event of a mine or other incident. Therefore, virtually any weapon system up to 500 kg can be fitted to it, including mechanical and remote-controlled towers for machine gun fire, anti-tank guided missiles, mortars or grenade launchers. For example, shooting tests with a gun station for a remote-controlled machine gun confirmed shooting accuracy at a target at a distance of 1.5 km.

International ambitions

More than a year after its introduction to the world, the Gerlach has moved from a prototype to a fully functional vehicle ready for deployment. The vehicle has passed demanding, often quite extreme tests. Its parameters have been confirmed by independent internationally respected authorities and the vehicle is also subjected to in-house and service life tests in cooperation with the Vyškov VTÚPV testing laboratory.

The project is aimed at all markets where the replacement of 4x4 tactical armoured



■ In testing the effectiveness of the parking brake system, the Gerlach achieved a slope of 83.9%.

from the outset. The aim was to maximise resistance while maintaining the defined cab comfort when occupied by a crew of 2+4, as well as the dynamics and main dimensions of the vehicle. "We addressed every detail, such as door hinges and locking protection, optimised the thickness of additional shields, improved the cab floor and many other details," explains safety cabin designer Peter Turňa.

The result is a solution that provides the vehicle with ballistic protection at NATO level STANAG AEP-55 4569 Volume 1 Level 3, meaning that the crew need not worry about rounds fired from hand-held assault



■ The vehicle provides superior capabilities in difficult terrain on various surfaces, including sand, mud or snow.

vehicles is or will be in underway. Besides Slovakia, the Gerlach has been presented also at international trade fairs in Slovenia, Poland, the Czech Republic, the United Kingdom, while its parameters have been presented also in other countries. It is currently participating in a competition for the replacement of 4x4 vehicles in the framework of the Pegasus programme for the Polish army. It is ready to fight also in an upcoming tender in Romania. In September last year a memorandum of understanding was signed with the Arab Organisation for Industrialisation in Egypt, which confirmed its interest in establishing the project in that country, but also sees its potential in wider cooperation in the Arab League and the African Union.

This project may bring special benefits also directly at home, in Slovakia. An indisputable benefit here is that the Slovak solution can give a boost to the domestic economy. In addition to the manufacturer itself, there are also development and engineering activities that a supplier usually retains in the country of origin. In the case of the Gerlach, however, the research and development activities, as well as know-how have, throughout the whole project duration, been concentrated locally. This solution would be a guarantee of value-added growth, the development of skills, knowledge, and at the same time would contribute to increasing the country's defence capabilities.

Zetor Engineering Slovakia is ready to ensure the entire product cycle of the vehicle from development through production, servicing, engineering and design activities of new applications that arise during the project lifetime. All activities will be carried out in domestic Slovak capacities in cooperation with strategic partners.

Further development of the project

Niet pochýb, že nové ATV spoločnosti Zetor Engineering Slovakia rozvírilo medzinárodné vody svojej kategórie vozidiel a môže byť povestnou novou šťoukou v rybníku. Tu sa však ambície spoločnosti a jej vývojárov nekončia. Už teraz sa v tíme Gerlach pracuje na ďalšom rozvoji projektu. A nemusí pritom zďaleka ísť „len“ o verziu s protimínovou ochranou STANAG 4569 AEP-55 Volume 2 Level 4a, 4b. Na výkresy sa už totiž dostala aj verzia ATV Zetor Gerlach 4x4 so 120 mm vezeným mínometom so zabudovanými hydraulickými podperami a spevneným rámom; verzia ATV Zetor Gerlach 4x4 Ambulancia; veliteľské vozidlo či verzia 6x6.

www.zetorengineering.sk

BASIC DATA	
Length	6250 mm
Width	2550 mm
Height	2600 mm
Engine power	240 kW (326 k)
Torque	1300 Nm
Transmission	6-speed automatic
Chassis	Ribbed portal frame
Axles	Independent suspension
Tyres	14 R20 with Central Inflation System (CTIS)
Wheelbase	3.6 m
Weight Maximum allowable up to 14.5 t	Maximum allowable up to 14.5 t
Modular cargo volume	2.3 m ³
Payload	Total 2.3 t - of which cargo 1.5 t
Components	Exclusively of EU origin
RIDE	
Clearance height	465 mm
Front approach angle	45 degrees
Rear approach angle	45 degrees
Side tilt - Drive up to 57%	- Driving up to 57% - Static lateral tilt up to 62.5%
Driving uphill	Up to 60%
Overcoming vertical obstacle	0.5 m
Overcoming the ditch	1 m
Wading	1.2 m
Turning radius	7.65 m
Max. speed	117 km/h
Fuel tank	220 l in 2 independent tanks
Range	600 km in combined terrain (off-road, terrain, road - 30%, 30%, 40%)
SAFETY	
Ballistic protection	STANAG 4569 AEP-55 Volume 1 Level 3
Antimine Protection	- STANAG 4569 AEP-55 Volume 2 Level 3a - STANAG 4569 AEP-55 Volume 3 Level 3b
Safety cabin	- Number of crew members - Additional modular armour with anti-mine V-shield - Separated and suspended double floor - Special anti-vibration and anti-vibration materials on the cab floor and floor - Crew compartment volume of 7.7 m ³
SYSTEMS AND LOGISTICS	
Subsystems	CBRN, communication systems, CTIS, data and voice communication
Weapon and communication systems	According to customer requirements
Logistics	STANAG 2165 Truck, Airbus 400 M, rail



■ 120 mm vezený mínomet so zabudovanými hydraulickými podperami a spevneným rámom



www.zetorengineering.sk
www.zetorengineering.cz
www.zetorgerlach.com



Zetor

ENGINEERING